

Evaluation of a Commercial-Scale Air Treatment System



B. Predicala, A. Alvarado, M. Girard, M. Belzile, S. Lemay, and J. Feddes



B. Predicala



Alvin Alvarado

SUMMARY

An air cleaning technology based on biotrickling filtration developed in previous phases of the project was scaled up and tested at the PSC swine grower-finisher facility. Results showed that the air treatment units were effective in reducing the levels of ammonia, dust, and odour from the airstream at the exhaust of the grow-finish rooms by about 77%, 92%, and 75%, respectively. Further work is needed to optimize the operation of these units in terms of water usage and to assess its year-round performance.

INTRODUCTION

Animal housing can emit substantial amounts of aerial contaminants such as odorous compounds, ammonia, hydrogen sulphide, airborne particulates, and pathogens. Since total removal of ammonia and odour is not possible within the confined animal space, the remaining option is to remove these contaminants from the exhaust air. Among all air cleaning technologies, biotrickling filters are considered to be the next development for animal housing since they are easier to manage and are smaller in size compared to other exhaust air filtration technologies. Various configurations of biotrickling filters and bioscrubbers have been studied and showed a very good potential for controlling emissions from pig buildings. A number of operating conditions have been specified for biotrickling filters. Design values have been suggested for bed height, bed cross-sectional area, packing nominal size, empty bed residence time (EBRT), pressure drop, air temperature, liquid recycle rate, pH of the recycled liquid, and some typical control parameters. However, further work is needed in order to realize the best design that will perform effectively when installed in actual swine production facilities.

The main goal of this study was to develop an air cleaning technology that will reduce the offensiveness of the exhaust air from a swine grower-finisher facility. Initial phases of this project were conducted in collaborating research institutions in Quebec to design and develop the air treatment unit (ATU) and to determine their optimum operating parameters in laboratory scale tests. This part of the study conducted at PSC utilized the outcomes from the previous phases as basis for designing a commercial-scale ATU, which was evaluated in the PSC swine barn for its effectiveness in reducing ammonia, dust, and odour emissions.

“Air treatment units were effective in reducing the levels of ammonia, dust, and odour from grower-finisher rooms by about 77%, 92%, and 75%, respectively”

RESULTS AND DISCUSSION

Experimental set-up

Figure 1 shows the conceptual and actual experimental set-up for this study. Three identical air treatment units (ATUs) were installed outside of three grow-finish rooms at PSC barn; the exhaust air from each room was ducted to each ATU and passed through the biotrickling filter inside each unit. Monitoring equipment and sensors were installed in the rooms and in each unit to collect data on gas and dust levels, environmental parameters, as well as operational parameters such as airflow rates and water consumption. For this experiment, each individual unit was a replicate for two treatments (prior and after the ATU; non treated and treated air), hence, completion of this trial yielded 3 replicates.

Effect on ammonia concentration

Table 1 shows the weekly average NH₃ concentration before (inside the room) and after each air treatment unit. Over the 12-week period, levels of ammonia inside the room ranged from 5.2 ppm to 69.1 ppm while the levels after the treatment units ranged from 4.0 ppm to 11.0 ppm. The difference in NH₃ levels before and after the unit was statistically significant ($p < 0.0001$) which means that the air filtration unit was able to significantly reduce levels of ammonia in the exhaust airstream before being released to the environment. It was also observed that the effectiveness of the ATU in reducing ammonia levels increased over time, i.e. on average,

from 22% reduction on week 1 to 77% on week 12. This implies that the air filtration units worked effectively even at the start of the trial; however, the reduction in NH₃ levels during the initial part of the trial was not that high because the incoming NH₃ levels were relatively low compared to the latter part of the trial when pigs were nearly market weights and NH₃ levels inside the room tended to be very high, thus, resulting to higher NH₃ reduction.

Effect on dust and odour concentration

Levels of total dust before and after the air treatment units are shown in Table 2. Significant reduction ($p < 0.0001$) in dust levels was observed after the exhaust air had passed through the treatment units. On average, dust concentration before the treatment units ranged from 0.255 mg/m³ to 1.301 mg/m³, which were reduced to about 0.089 mg/m³ – 0.266 mg/m³ after the units. Similar to ammonia, dust levels after the treatment units were not significantly different ($p = 0.183$) over the 7 monitored weeks; however, dust levels inside the rooms (before the units) increased significantly ($p < 0.0001$) with time. This has resulted to higher dust reduction achieved at the latter part of the trial when pigs were nearing market weights. Maximum dust reduction was about 92%, which was achieved on week 12 while the least reduction was about 65% during week 3.

The impact of the air treatment units on odour concentration was not as readily evident compared to ammonia and dust, though statistically significant reduction ($p = 0.017$) in overall odour levels was observed after passing through the treatment units. On average, odour concentration inside the room (before treatment) was about 815 ± 419 OU/m³ and was reduced to about 553 ± 208 OU/m³ after the air treatment units.

Water consumption

On average, the air treatment units consumed about 537.5 ± 113.3 liters of water per day; ATU 1 had the highest (663.0 L/day) while ATU 3 had the least (442.9 L/day). Wide variations in water consumption between ATUs can be attributed to the differences in frequency of replenishing the water in each particular unit, i.e., draining about 2 inches depth of water from the unit and then adding the same volume, to maintain the water electrical conductivity below 7.5 μ S. Throughout the trial, the water in ATU 1 was replenished 16 times compared to 11 times for ATU 3; this could be related to NH₃ removal because as shown in Table 1, ATU 1 had the highest NH₃ removal efficiency while ATU 3 had the least. Periodically draining the contaminated water and then adding fresh water into the ATU was necessary to prevent the water from getting saturated, which consequently can adversely impact the biofilm activity on the biotrickling filter media, thereby reducing the contaminant removal efficiency of the system.

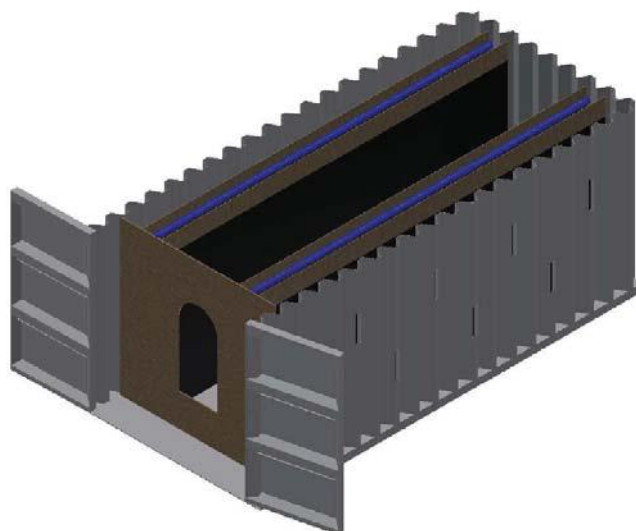

Figure 1. Conceptual diagram of the interior of each ATU



Figure 2. Actual installation of air cleaning unit at a grower finisher room

CONCLUSIONS

Based on the findings from this trial, the following conclusions can be made:

1. The biotrickling air treatment units installed at the exhaust of swine grow-finish rooms were effective in reducing the levels of ammonia, dust, and odour by about 77%, 92% and 75%, respectively.
2. The biotrickling units were able to reduce the levels of ammonia even at the initial stage of the trial, with the ammonia levels after the filter almost remaining the same throughout the trial. Hence, the percent reduction in ammonia increased as the initial ammonia concentration before the filter increased.
3. No clear diurnal pattern in ammonia reduction from the air treatment units was observed.
4. Water consumption tended to increase as the biotrickling units remove more contaminants from the air.
5. The biotrickling air treatment units had no adverse or beneficial impact on the performance of pigs in the room.

Table 1. Weekly concentration of ammonia (in ppm) before and after each ATU and the corresponding removal efficiency (RE).

Trial week #	ATU 1			ATU 2			ATU 3			Average		
	Before	After	RE (%)	Before	After	RE (%)	Before	After	RE (%)	Before	After	RE (%)
3	9.9	6.8	29.7	10.2	8.0	18.6	5.2	4.0	17.7	8.4	6.3	22.0
5	27.9	6.9	72.2	28.9	8.7	67.3	9.0	4.9	43.3	21.9	6.8	60.9
7	24.3	8.6	65.3	20.0	6.4	67.2	9.6	6.2	39.5	18.0	7.1	57.3
8	29.1	7.3	74.5	24.2	7.2	70.2	11.8	6.5	44.1	21.7	7.0	62.9
9	45.5	6.4	85.4	31.6	8.2	73.4	19.6	7.2	62.8	32.2	7.3	73.9
10	52.8	8.5	83.8	34.9	9.8	70.9	19.4	7.2	61.9	35.7	8.5	72.2
11	48.8	7.9	83.5	33.6	8.7	73.4	21.4	8.4	59.4	34.6	8.4	72.1
12	69.1	11.0	83.5	48.8	9.1	79.1	26.0	8.7	67.7	48.0	9.6	76.8
Ave	38.4	7.9	72.2	29.0	8.3	65.0	15.3	6.6	49.6			

Table 2. Levels of total dust (in mg/m3) measured inside the room (prior) and after each ATU and the corresponding removal efficiency (RE).

Trial week #	ATU 1			ATU 2			ATU 3			Average		
	Before	After	RE (%)	Before	After	RE (%)	Before	After	RE (%)	Before	After	RE (%)
3	0.039	0.034	12.8	0.115	0.060	47.4	0.612	0.172	71.9	0.255	0.089	65.2
5	0.341	0.046	86.4	0.314	0.119	62.1	0.764	0.260	66.0	0.473	0.142	70.0
7	0.504	0.052	89.7	0.681	0.181	73.4	1.160	0.175	84.9	0.781	0.136	82.6
9	0.568	0.320	43.7	0.909	0.157	82.7	1.572	0.322	79.5	1.016	0.266	73.8
10	1.067	0.245	77.1	1.086	0.298	72.6	1.477	0.234	84.2	1.210	0.259	78.6
11	1.075	0.018	98.3	1.222	0.222	81.8	1.605	0.491	69.4	1.301	0.244	81.2
12	1.005	0.092	90.9	1.039	0.173	83.3	1.729	0.039	97.7	1.258	0.101	91.9
Ave	0.657	0.115	71.3	0.767	0.173	71.9	1.274	0.242	79.1			

ACKNOWLEDGEMENTS

Strategic funding provided by the Saskatchewan Pork Development Board, Alberta Pork, Manitoba Pork Council and the Saskatchewan Ministry of Agriculture. The authors would like to acknowledge the Canadian Swine Research and Development Cluster (CSRDC) for the financial support to this research project.